

Tapped Reduced Base Metric Thread

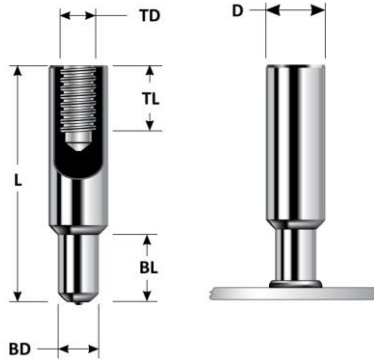

Metric Thread:

Diameter "D"	Minimum Length "L"	Tap Length "TL"	Tap Diameter "TD"	Fillet Height* "FH"	Fillet Diameter* "FD"	Est. Burn* Off
.275	20mm	8mm	M4-7	3.0 +/-1.0	9.0	2.0
.312	25mm	8mm	M6-1	3.0 +/-1.0	9.5	3.0
.375	25mm	8mm	M8-1.25	3.2 +/- 1.0	12.0	3.0
.500	30mm	10mm	M10-1.25	3.9 +/- 1.0	13.0	3.0
.625	40mm	10mm	M12-1.75	4.8 +/- 1.0	18.5	4.7
.750	50mm	12mm	M16-2.0	4.8 +/- 1.0	22.0	4.7

* Approximate values
Other sizes available
Contact us if you have a special requirement

Material:

	Low Carbon Steel	Stainless Steel
Material:	ASTM A108 C1010-C1020 C-0.23% max; P-0.04% max MN-0.90% max; S-0.05% max	ASTM A276 302HQ/304/304L STANDARD 18-8
Mechanical Properties:	Min. Tensile Type A61,000 psi (420 MPa) Min. Yield Type A49,000 psi (340 MPa) Min. Tensile Type B65,000 psi (450 MPa) Min. Yield Type B51,000 psi (340 MPa)	Other Grades Available Upon Request
Plating:	Available As Special Request	Plating Does Not Apply To Stainless Steel
Annealing:		Studs Are Annealed Where Required